

KAM

INSTRUCTION MANUAL

Kam KMH

Moving head lighting series

M A N U A L V E R S I O N 1 . 0
0 5 - 1 1 - 1 4

For the latest instruction manual updates and information on the entire Kam range visit:

www.kam.co.uk

Kam products are manufactured by: **Lamba plc**, Unit 1, Southfields Road, Dunstable, Bedfordshire, United Kingdom LU6 3EJ
Telephone: (+44) (0)1582 690600 • Fax: (+44) (0)1582 690400 • Email: mail@lambapl.com • Web: www.lambapl.com

If this product is ever no longer functional please take it to a recycling plant for environmentally friendly disposal.

Due to continuous product development, specifications and appearance are subject to change.

© Copyright Lamba plc. E&OE.

Thank you for purchasing this Kam product, we are sure that it will serve you for many years to come.

To optimise its performance, please read these instructions carefully to familiarise yourself with the basic operations of the unit. Please retain them for future reference. This unit has been tested at the factory before being shipped to you. To prevent or reduce the risk of electrical shock or fire, do not expose the unit to rain or moisture. To prevent a fire hazard, do not expose the unit to any naked flame sources. Unplug this apparatus during lightning storms or if it is unlikely to be used for long periods of time.

When installing the unit, please ensure you leave enough space around the unit for ventilation. Slots and openings in the unit are provided for ventilation to ensure reliable operation of the product and to protect it from overheating. To prevent fire hazard, the openings should never be blocked or covered.

The unit is powered by the mains, always handle the power cable by the plug. Never pull out the plug by pulling on the cable. Never touch the power cable when your hands are wet as this could cause an electric shock. Do not tie a knot in the cable. The power cable should be placed such that it is not likely to be stepped on. A damaged power cable can cause a fire or give you an electrical shock. Check the power cord periodically, if you ever find that it is damaged, replace it before using the unit again. Contact your retailer for a replacement.

The voltage of the available power supply differs according to country or region. Be sure that the power supply voltage of the area where this unit is to be used meets the requirements of the unit.

The lightning flash symbol inside a triangle is to alert the user to the presence high voltage within the unit's enclosure that may be of sufficient power to constitute a risk of electrical shock to persons. Caution: to prevent the risk of electric shock, do not attempt to open the unit. No user-serviceable parts inside. Refer all servicing to qualified service personnel. The exclamation mark inside a triangle is intended to alert the user to the presence of important operating and maintenance instructions in the literature accompanying the appliance. Please read and pay attention to all laser safety warning sticker labels on the unit.

Select the installation location of your unit carefully. Avoid placing it in direct sunlight or locations subject to vibration and excessive dust. Do not use the unit where there are extremes in temperature (below 41°F / 5°C or exceeding 95°F / 35°C).

Unpacking and safety Please unpack your new product carefully. Your new product should reach you in perfect condition. Please check that no damage has occurred during transit. If any damage is found, do not operate your unit. Please contact the retailer you purchased it from immediately. If there is any damage to the mains cable do not use the device. Always disconnect the unit from the mains supply when carrying out any cleaning of the unit.

Manufacturer declarations



In compliance with the following requirements: **RoHS Directive (2002/95/EU)** and **WEEE Directive (2002/96/EU)**. If this product is ever no longer functional please take it to a recycling plant for environmentally friendly disposal.

CE declaration of conformity

R&TTE Directive (1999/5/EU), EMC Directive (2004/108/EU), Low Voltage Directive (2006/95/EU).

The declarations are available on application from certification@lambapl.com

Before putting the devices into operation, please observe the respective country-specific regulations.

AC power

The unit is supplied with a power plug appropriate to its voltage. Should any other connections be required they must be carried out with the following configuration:

Cable (EU)	Cable (US)	Pin	International
Brown	Black	Live	L
Light blue	White	Neutral	N
Yellow/green	Green	Earth	

DMX-512 connection

If you are using a standard DMX controller, you can connect the DMX output of the controller directly to the DMX input of the first unit in a DMX chain. If you wish to connect a DMX controller with other XLR outputs you will need to use adapter cables.

DMX OUT



XLR female

DMX IN

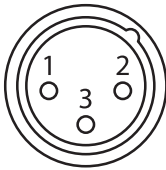

XLR male

1 = ground 2 = minus signal (-) 3 = plus signal (+)

Connect the DMX output of the first unit in a DMX chain with the DMX input of the next unit in the chain. Always connect the the output of one unit with the input of the next unit until all units are connected. If you use a controller with 5 pin DMX connection you will need to use a 5 pin to 3 pin adapter.

Overhead rigging

Important - the installation must be carried out by qualified service personal only. Improper installation can result in serious injuries and /or damage to property. Overhead rigging required extensive experience. Working load limits should be respected, certified installation materials should be used, the installed unit should be inspected regularly for safety.

- Make sure the area below the installation place is free from unwanted persons during rigging, de-rigging and servicing.
- Locate the unit in a well ventilated spot, far away from any flammable materials and/or liquids. The fixture must be fixed at **least 50cm** from surrounding walls
- The device should be installed out of reach of people and outside of areas where persons may walk by or be seated.
- Before rigging make sure that the installation area can hold minimum point load of 10 times the device's weight.
- The device should be well fixed; a free swinging mounting is dangerous.
- Do not cover any ventilation opening as this may result in overheating

Before first time use, the unit should be inspected for safety. Inspection the unit regularly every year.

Overview

There are currently three different units in the Kam KMH series. These are the quad moving head KMH4, the dual head KMH2 and the single head KMH1.

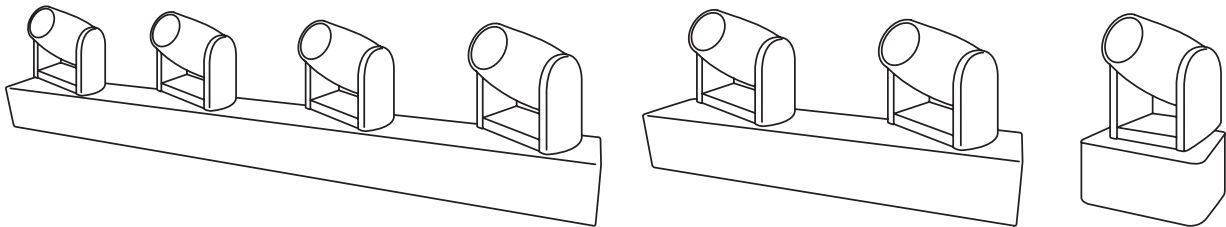

The KMH series have been designed to link together in Master/Slave mode. Whether you have a four head, a two head or a single head unit, each of the individual moving heads can be accessed and operated as a single unit using the built-in settings, or via a DMX controller or DMX software. You will notice that each moving head has its own blue LED display and set of function buttons. Operation and selection of the correct mode for each head is very important to get the units to run in the way that you want them to perform.

In simple terms, the individual heads can be operated in either Master/Slave mode (where all heads perform in exactly the same way) or in individual DMX mode (where each moving head is controlled separately).

After connecting your Kam Moving Head unit to the mains, use the Function Setting menu on the unit to set the operating mode.

Function Setting blue LED display(s)

FUNCTION SETTING

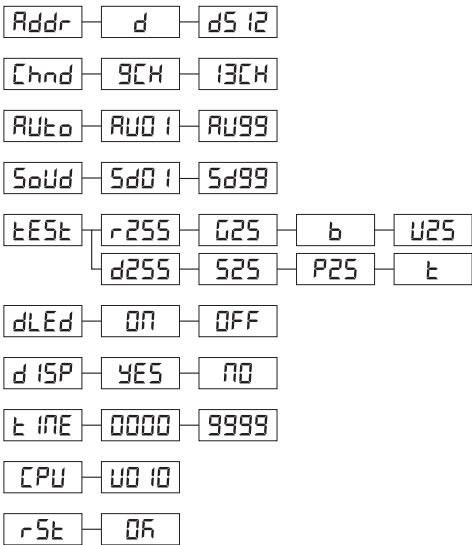

Display	Function
Addr	Set the DMX address for the unit.
Chnd	Set the DMX channel mode. Either 9 or 13 channels.
AUto	Set the unit to Auto mode. Set the pre-programmed show (from 01-99).
SoLd	Set the unit to Sound-to-Light mode. Set the pre-programmed show (from 01-99).
tEst	Set the unit to run through a series of self tests.
dLEd	Set the rear panel Function Setting LED display to turn off automatically (OFF) or remain on (ON).
dISP	Rotate the rear panel Function Setting LED display 180°. Use when unit is mounted upside down.
tINE	Unit runtime.
CPU	Software version.
rSt	Resets the unit.

Quick Start Guide

Running in Auto mode

- 1) Use the rear panel Function Setting MENU button on the first moving head to find and select the **AUto** function.
- 2) Press the ENTER button to make your selection.
- 3) Select any other moving heads on the unit and select **Addr** and then set each unit to the same number e.g. **0001**.
- 4) Press the ENTER button to make your selection.

Your Kam KMH moving head(s) will now operate in Auto mode.

Running in DMX Master/Slave mode (where all heads perform in exactly the same way)

Whether you have a 4, 2 or single head unit, this is the settings to get all heads to 'copy' the actions of the first head or unit.

Start by setting the first unit or head to be the Master by pressing the MENU button and selecting **AUto** followed by the ENTER button. Next set all other heads/units to be Slaves by pressing their MENU button until the display shows **Addr**, press ENTER then set each head/unit to the same number e.g. **0001**. Then press the ENTER button to confirm your choice. Each head connected to the Master will now work as a Slave. This process needs to be completed for each head and/or units. If you are connecting multiple units, these will need to be connected via a DMX cable. The routing is as follows: connect a DMX cable from the DMX Output of the Master unit to the DMX Input of the next unit, then another DMX cable from the second unit's DMX Output to the DMX input of the next unit and so on for all units connected in the chain.

Running in Individual DMX mode

Whether you have a 4, 2 or single head unit, this is the settings to control each head separately and have full control over its individual features. This makes this product great for installations and creative DJs. All KMH units have two DMX operating modes, you can choose either 13 or 9 channel operation.

Setting the DMX address

Set each head to DMX address mode by pressing the MENU button until the display shows **Addr** press the ENTER button and then you will see the address menu e.g. **0001**. This number is the DMX address of each individual head. Choose a number and then press the ENTER button to confirm your choice.

9 DMX channel mode

Channel	Function	Value	Function
1	Dimmer	0-255	From dark to bright
2	Strobe	0-255	From slow to fast
3	Red	0-255	Red, from dark to bright
4	Green	0-255	Green, from dark to bright
5	Blue	0-255	Blue, from dark to bright
6	White	0-255	White, from dark to bright
7	Effects	0-002	RGBW dimmer
		3-223	Colour mixing
		224-234	Snap colour changes from slow to fast
		235-243	Fading colour changes from slow to fast
		244-255	Sound control from slow to fast
8	Pan	0-255	Pan
9	Tilt	0-255	Tilt

13 DMX channel mode

Channel	Function	Value	Function
1	Dimmer	0-255	From dark to bright
2	Strobe	0-255	From slow to fast
3	Red	0-255	Red, from dark to bright
4	Green	0-255	Green, from dark to bright
5	Blue	0-255	Blue, from dark to bright
6	White	0-255	White, from dark to bright
7	Effects	0-255	RGBW dimmer
		3-223	Colour mixing
		224-234	Snap colour changes from slow to fast
		235-243	Fading colour changes from slow to fast
		244-255	Sound control from slow to fast
8	Effects speed	0-255	From slow to fast
9	Pan	0-255	Pan
10	Tilt	0-255	Tilt
11	Pan speed	0-255	From fast to slow
12	Tilt speed	0-255	From fast to slow
13	Reset	0-50	No function
		51-101	Pan reset
		102-152	Tilt reset
		153-203	Pan/Tilt reset
		204-255	Reset

Important note on DMX addresses

When assigning separate DMX address to different moving heads, there needs to be 'separation' between each number of the DMX addresses chosen. For example, in 9 channel DMX mode, there needs to be 9 digit difference between the first head's DMX address and the second head's DMX address and then another 9 digit difference between the second head and the third head. This changes to a 13 digit gap needed when operating in 13 channel DMX mode. The tables below should give you a guide to DMX address setting.

DMX address setting in 9 Channel mode

Unit/head	DMX address
1	001
2	010
3	019
4	028
5	037
6	046
7	055
and so on	Add 9

DMX address setting in 13 Channel mode

Unit/head	DMX address
1	001
2	014
3	027
4	040
5	053
6	066
7	079
and so on	Add 13

Technical specifications

Kam KMH1	RGBW multicolour mini moving head
Mains power	AC 110-240V 50/60Hz IEC mains input and output
Control modes	DMX512 / Auto / Sound-to-Light / Master/Slave
Light source	1 x 10w CREE 4-in-1 LED
Colours	Red, green, blue and white
Control setting	4 buttons plus function setting LED display
Finish	Powder black metal housing
Operating temperature	10~40°
DMX512 connections	3 pins XLR input (male) and output (female)
DMX512 channels	9 / 13
Dimensions (WxDxH)	170 x 100 x 260mm
Nett weight	1.5Kg

Kam KMH2	RGBW multicolour dual moving head bar
Mains power	AC 110-240V 50/60Hz IEC mains input and output
Control modes	DMX512 / Auto / Sound-to-Light / Master/Slave
Light source	2 x 10w CREE 4-in-1 LED
Colours	Red, green, blue and white
Control setting	4 buttons plus function setting LED display x 2
Finish	Powder black metal housing
Operating temperature	10~40°
DMX512 connections	3 pins XLR input (male) and output (female)
DMX512 channels	9 / 13
Dimensions (WxDxH)	515 x 85 x 260mm (not including brackets)
Nett weight	4.3Kg

Kam KMH4	RGBW multicolour quad moving head bar
Mains power	AC 110-240V 50/60Hz IEC mains input and output
Control modes	DMX512 / Auto / Sound-to-Light / Master/Slave
Light source	4 x 10w CREE 4-in-1 LED
Colours	Red, green, blue and white
Control setting	4 buttons plus function setting LED display x 4
Finish	Powder black metal housing
Operating temperature	10~40°
DMX512 connections	3 pins XLR input (male) and output (female)
DMX512 channels	9 / 13
Dimensions (WxDxH)	1030 x 85 x 260mm (not including brackets)
Nett weight	10.5Kg